

3-Axis Magnetic Sensor

QMC5883L



The QMC5883L is a multi-chip three-axis magnetic sensor. This surface -mount, small sized chip has integrated magnetic sensors with signal condition ASIC, targeted for high precision applications such as compassing, navigation and gaming in drone, robot, mobile and personal hand-held devices.

The QMC5883L is based on our state-of-the-art, high resolution, magneto-resistive technology licensed from Honeywell AMR technology. Along with custom-designed 16-bit ADC ASIC, it offers the advantages of low noise, high accuracy, low power consumption, offset cancellation and temperature compensation. QMC5883L enables 1° to 2° compass heading accuracy. The I²C serial bus allows for easy interface.

The QMC5883L is in a 3x3x0.9mm³ surface mount 16-pin land grid array (LGA) package.

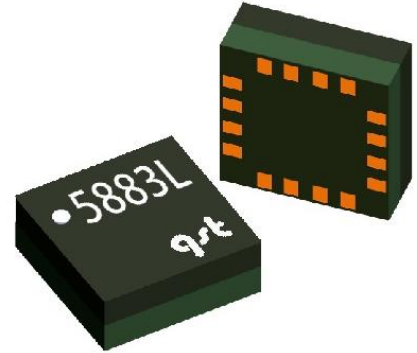

FEATURES

- ▶ 3-Axis Magneto-Resistive Sensors in a 3x3x0.9 mm³ Land Grid Array Package (LGA), guaranteed to operate over an extended temperature range of -40 °C to +85 °C.
- ▶ 16 Bit ADC With Low Noise AMR Sensors Achieves 5 Milli-Gauss Field Resolution
- ▶ Wide Magnetic Field Range (±8 Gauss)
- ▶ Temperature Compensated Data Output and Temperature Output
- ▶ I²C Interface with Standard and Fast Modes.
- ▶ Wide Range Operation Voltage (2.16V To 3.6V) and Low Power Consumption (75µA)
- ▶ Lead Free Package Construction
- ▶ Software And Algorithm Support Available

BENEFIT

- ▶ Small Size for Highly Integrated Products. Signals Have Been Digitized And Calibrated.
- ▶ Enables 1° To 2° Degree Compass Heading Accuracy , Allows for Navigation and LBS Applications
- ▶ Maximizes Sensor's Full Dynamic Range and Resolution
- ▶ Automatically Maintains Sensor's Sensitivity Under Wide Operating Temperature Range
- ▶ High-Speed Interfaces for Fast Data Communications. Maximum 200Hz Data Output Rate
- ▶ Compatible with Battery Powered Applications
- ▶ RoHS Compliance
- ▶ Compassing Heading, Hard Iron, Soft Iron, and Auto Calibration Libraries Available

QMC5883L

1 INTERNAL SCHEMATIC DIAGRAM

1.1 Internal Schematic Diagram

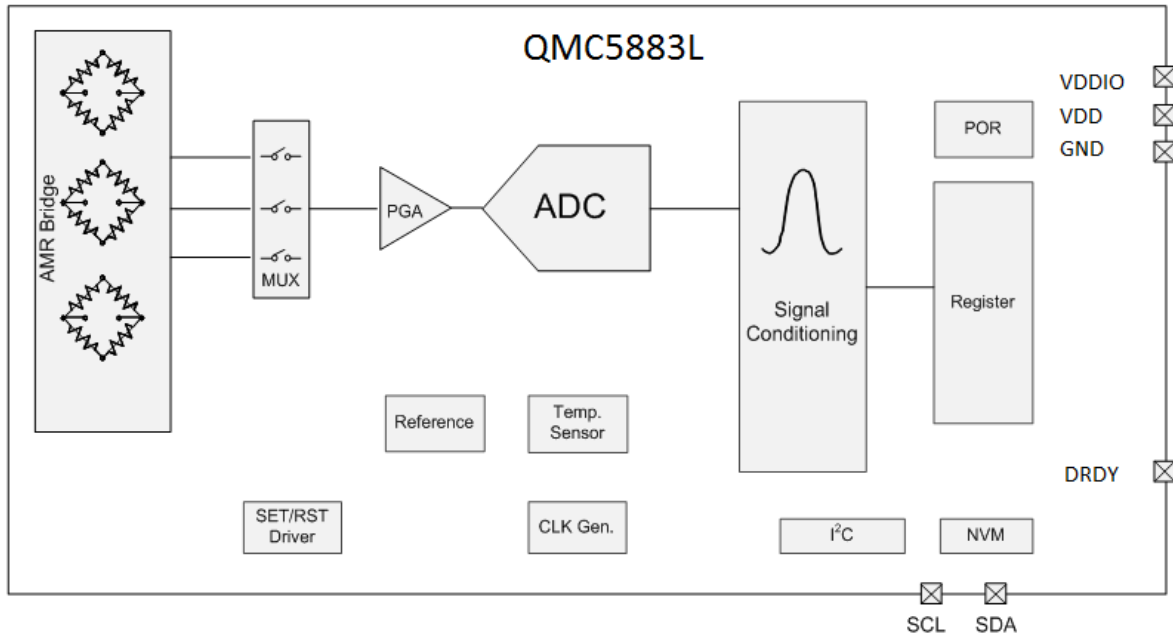

Figure 1. Block Diagram

Table 1. Block Function

Block	Function
AMR Bridge	3 axis magnetic sensor
MUX	Multiplexer for sensor channels
PGA	Programmable gain amplifier for sensor signals
ADC	16 bit Analog-to-Digital converter
Signal Conditioning	Digital blocks for magnetic signal calibration and compensation
I ² C	Interface logic data I/O
NVM	Non-Volatile memory for calibrated parameters
SET/RST Driver	Internal driver to initialize magnetic sensor
Reference	Voltage/Current reference for internal biasing
Clock Gen.	Internal oscillator for internal operation
POR	Power on reset
Temperature Sensor	Temperature sensor for internal sensitivity /offset compensation, and temperature output

2 SPECIFICATIONS AND I/O CHARACTERISTICS

2.1 Product Specifications

Table 2. Specifications (* Tested and specified at 25°C except stated otherwise.)

Parameter	Conditions	Min	Typ	Max	Unit
Supply Voltage	VDD	2.16		3.6	V
I/O Voltage	VDDIO	1.65		3.6	V
Standby Current	Total Current on VDD and VDDIO		3		μA
Continuous Mode Current	Low/High Power Mode (OSR=64 or 512)	ODR = 10Hz	75/100		μA
		ODR = 50Hz	150/250		μA
		ODR = 100Hz	250/450		μA
		ODR = 200Hz	450/850		μA
Peak Current in Active State	Peak Current on VDD and VDDIO During Measurement		2.6		mA
Sensor Field Range	Full Scale	-8		+8	Gauss
Dynamic Output Field Range	Programmable with 2 options	±2		±8	Gauss
Sensitivity ^[1]	Field Range = ±2G		12000		LSB/G
	Field Range = ±8G		3000		LSB/G
Linearity (Best fit linear curve)	Field Range = ±2G		0.1		%FS
Hysteresis	All Ranges		0.3		%FS
Cross Axis Sensitivity	Cross field = 1 Gauss, Applied = ±2 Gauss		0.1		%/G
Offset			±10		mG
Sensitivity Tempco	Ta = -40°C~85°C		±0.05		%/°C
Temperature Sensor Sensitivity	Ta = -40°C~85°C		100		LSB/°C
Digital Resolution	Change with Gain	0.1		1.0	mGauss
Field Resolution	Standard deviation 100 Data, FS ±2G		5		mGauss
Output Data Rate	Programmable. 10Hz/50Hz/100Hz/200Hz	10		200	Samples/sec
X-Y-Z Orthogonality	Sensitivity Directions		90±1		degree
Operating Temperature		-40		85	°C
ESD	HB Model	2000			V
	Machine Model	200			

Note [1]: Sensitivity is calibrated at zero field, it is slightly decreased at high fields.

QMC5883L

2.2 Absolute Maximum Ratings

Table 3. Absolute Maximum Ratings (Tested at 25°C except stated otherwise.)

Parameter	MIN.	MAX.	Units
VDDIO	-0.3	5.4	V
VDD	-0.3	5.4	V
Storage Temperature	-40	125	°C
Exposed to Magnetic Field (all directions)		50000	Gauss
Reflow Classification	MSL 3, 260 °C Peak Temperature		

2.3 I/O Characteristics

Table 4. I/O Characteristics

Parameter	Symbol	Pin	Condition	Min.	TYP.	Max.	Unit
Voltage Input High Level 1	V_{IH1}	SDA, SCL		$0.7 \cdot V_{DIO}$		$V_{DIO} + 0.3$	V
Voltage Input Low Level 1	V_{IL1}	SDA, SCL		-0.3		$0.3 \cdot V_{DIO}$	V
Voltage Output High Level	V_{OH}	INT	Output Current $\geq -100\mu A$	$0.8 \cdot V_{DIO}$			V
Voltage Output Low Level	V_{OL}	INT, SDA	Output Current $\leq 100\mu A$ (INT) Output Current $\leq 1mA$ (SDA)			$0.2 \cdot V_{DIO}$	V

3 PACKAGE PIN CONFIGURATIONS

3.1 Package 3-D View

Arrow indicates direction of magnetic field that generates a positive output reading in normal measurement configuration.

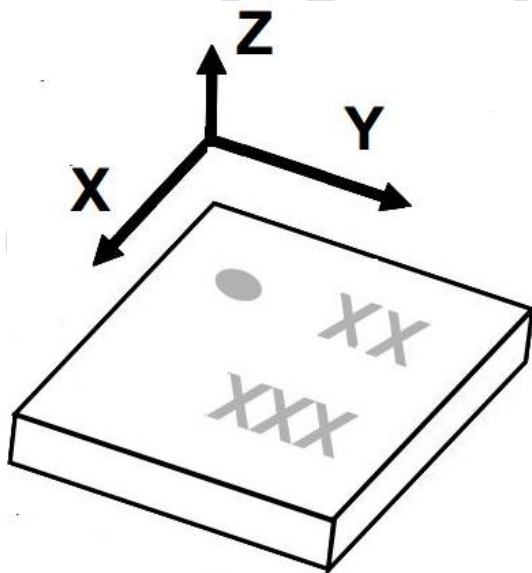
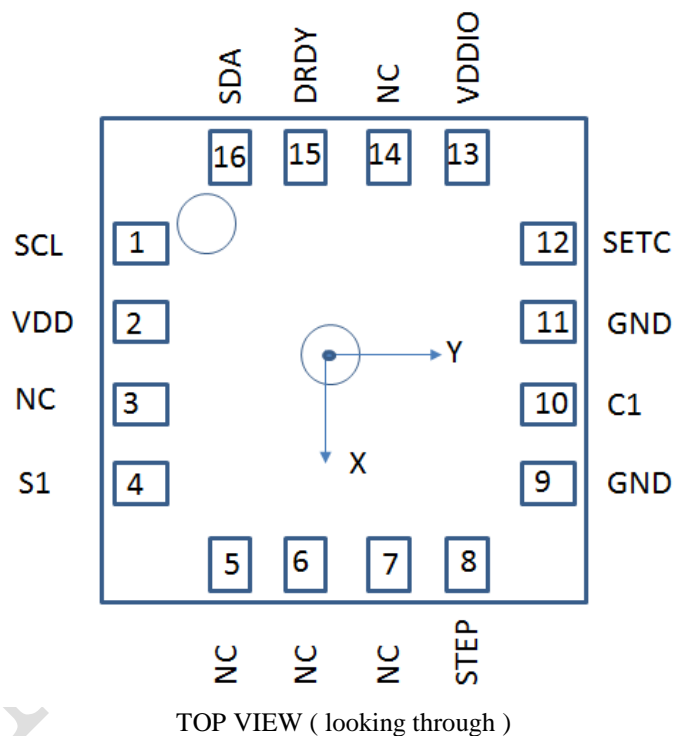

Figure 2. Package 3-D View

Table 5. Pin Configurations

PIN No.	PIN NAME	Function
1	SCL	Serial Clock – I2C Master/Slave Clock
2	VDD	Power Supply (2.16V to 3.6V)
3	NC	Not to be Connected
4	S1	Tie to VDDIO
5	NC	Not to be Connected
6	NC	Not to be Connected
7	NC	Not to be Connected
8	SETP	Set/Reset Strap Positive – S/R Capacitor (C2) Connection
9	GND	Supply Ground
10	C1	Reservoir Capacitor (C1) Connection
11	GND	Supply Ground
12	SETC	S/R Capacitor (C2) Connection – Driver Side
13	VDDIO	IO Power Supply (1.71V to VDD)
14	NC	Not to be Connected
15	DRDY	Data Ready, Interrupt Pin. Default low. Data ready high until data register is read.
16	SDA	Serial Data – I2C Master/Slave Data



3.2 Package Outlines

3.2.1 Package Type
LGA (Land Grid Array)

3.2.2 Package Size:
3mm (Length)*3mm (Width)*0.9mm (Height)

QMC5883L

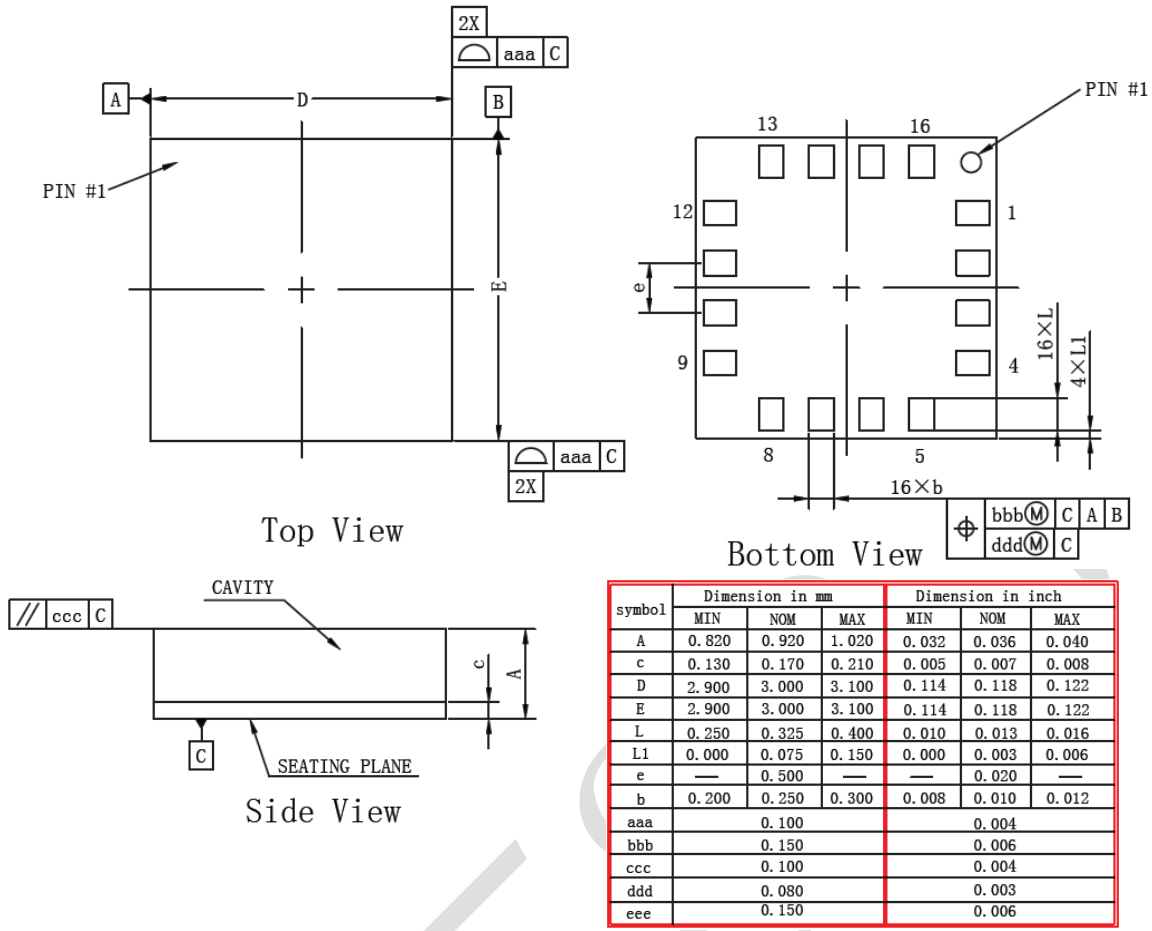

Figure 3. Package Size

3.2.3 Marking:

Tracking code:

Text1: D Fixed code, X System generated for Customer type 9th bit

Text2: System generated for front 2 of Customer Batch number

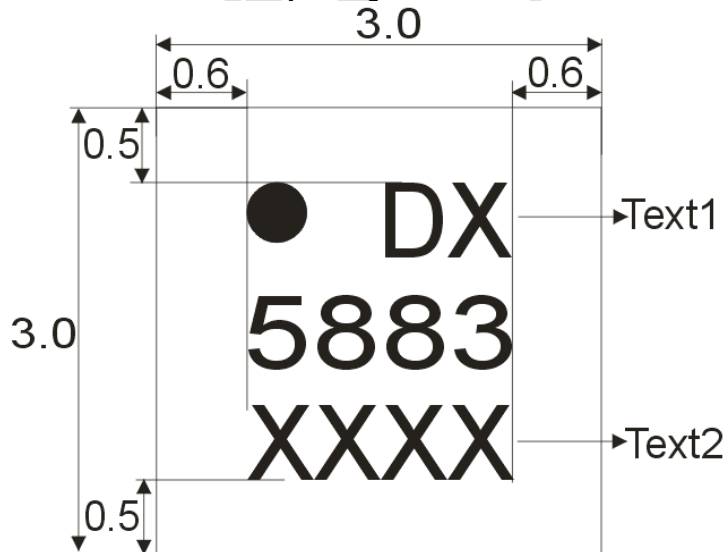

Figure 4. Chip Marking

4 EXTERNAL CONNECTION

4.1 Dual Supply Connection

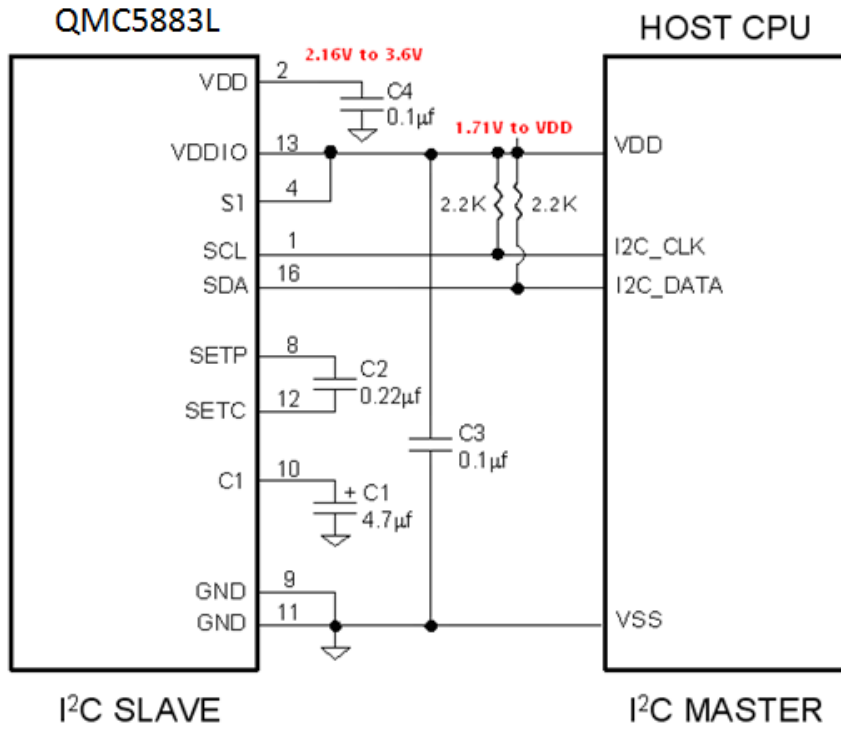

Figure 5. Dual Supply Connection

4.2 Single Supply connection

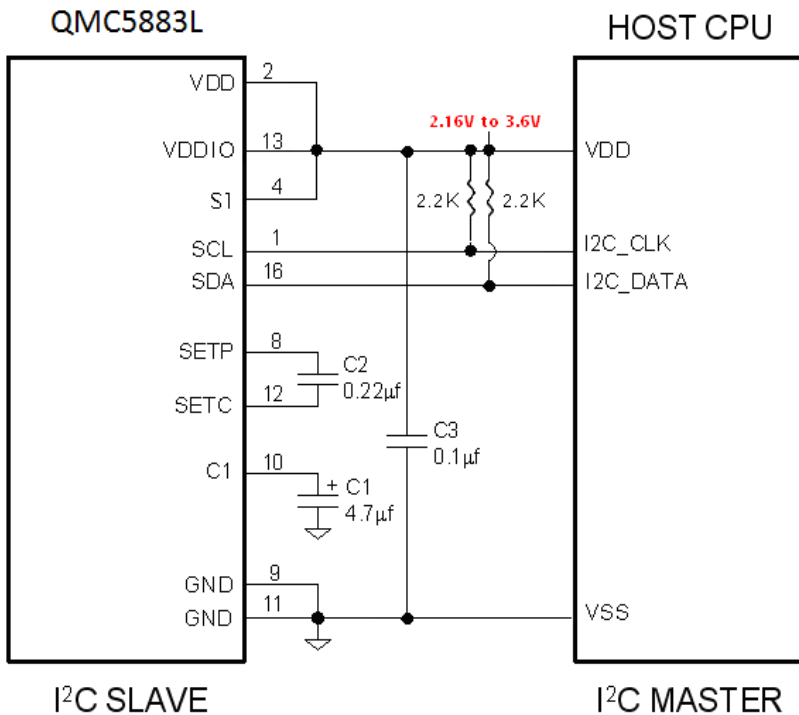

Figure 6. Single Supply Connection

QMC5883L

4.3 Mounting Considerations

The following is the recommend printed circuit board (PCB) footprint for the QMC5883L. Due to the fine pitch of the pads, the footprint should be properly centered in the PCB.

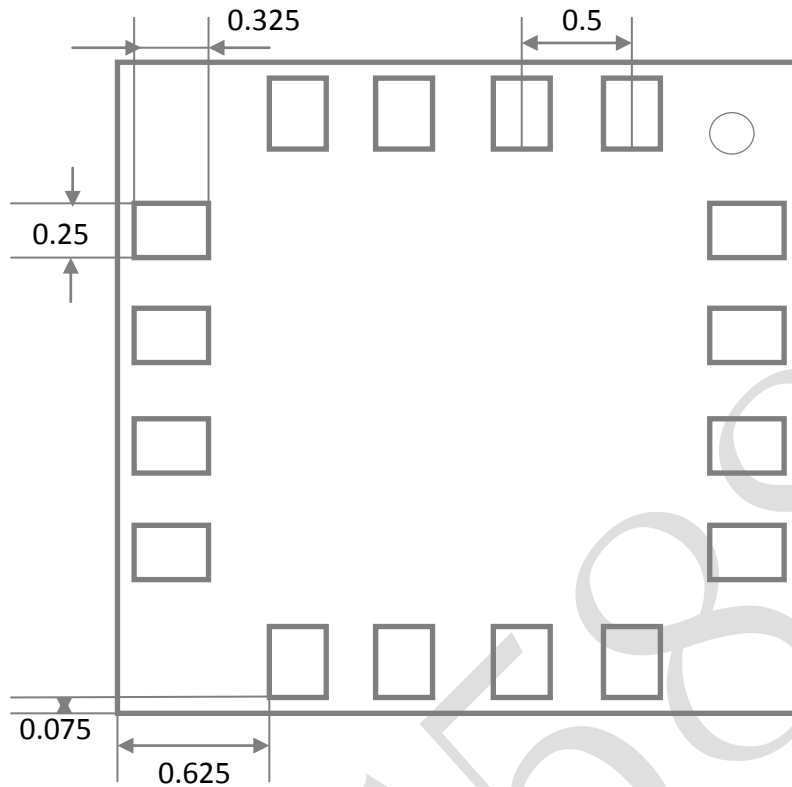

Figure 7. QMC5883L PCB footprint

4.4 Layout Considerations

Besides keeping all components that may contain ferrous materials (nickel, etc.) away from the sensor on both sides of the PCB, it is also recommended that there is no conducting copper line under/near the sensor in any of the PCB layers.

4.4.1 Solder Paste

A 4 mil stencil and 100% paste coverage is recommended for the electrical contact pads.

4.4.2 Reflow Assembly

This device is classified as MSL 3 with 260°C peak reflow temperature. As specified by JEDEC, parts with an MSL 3 rating require baking prior to soldering, if the part is not kept in a continuously dry (< 10% RH) environment before assembly. Reference IPC/JEDEC standard J-STD-033 for additional information.

No special reflow profile is required for QMC5883L, which is compatible with lead eutectic and lead-free solder paste reflow profiles. QST recommends adopting solder paste manufacturer's guidelines. Hand soldering is not recommended.

4.4.3 External Capacitors

The external capacitors C1 should be ceramic type with low ESR characteristics. The exact ESR value is not critical, but values less than 200 milli-ohms are recommended. Reservoir capacitor C1 is nominally 4.7 μF in capacitance. Low ESR characteristics may not be in many small SMT ceramic capacitors (0402), so be prepared to up-size the capacitors to gain low ESR characteristics.

5 BASIC DEVICE OPERATION

5.1 Anisotropic Magneto-Resistive Sensors

The QMC5883L magneto-resistive sensor circuit consists of tri-axial sensors and application specific support circuits to measure magnetic fields. With a DC power supply is applied to the sensor two terminals, the sensor converts any incident magnetic field in the sensitive axis directions to a differential voltage output. The ASIC then amplifies and processes the signal to have a digital output.

The device has an offset cancellation function to eliminate sensor and ASIC offsets. It also applies a self-aligned magnetic field to restore magnetic state before each measurement to ensure high accuracy. Because of these features, the QMC5883L doesn't need to calibrate every time in most of application situations. It may need to be calibrated once in a new system or a system changes a new battery.

5.2 Power Management

There are two power supply pins to the device. VDD provides power for all the internal analog and digital functional blocks. VDDIO provides power for digital I/O and logic. It is possible to work with VDDIO equal to VDD, the single supply mode, or with VDDIO lower than VDD, the dual supply mode.

The device should turn-on both power pins in order to operate properly. When the device is powered on, all registers are reset by POR, then the device transits to the standby mode and waits for further commands.

Table 6 provides references for four power states. Transitions between power state 2 and power state 3 are prohibited, due to leakage current concerns.

Table 6: Power States

Power State	VDD	VDDIO	Power State description
1	0V	0V	Device Off, No Power Consumption
2	0V	1.65v~3.6v	Device Off, Unpredictable Leakage Current on VDD due to Floating Node.
3	2.16v~3.6v	0	Device Off, Same Current as Standby Mode
4	2.16v~3.6v	1.65v~3.6v	Device On, Normal Operation Mode, Enters Standby Mode after POR

5.3 Power On/Off Time

After the device is powered on, some time periods are required for the device fully functional. The external power supply requires a time period for voltage to ramp up (PSUP), it is typically 50 milli-second. However it isn't controlled by the device. The Power –On –Reset time period (PORT) includes time to reset all the logics, load values in NVM to proper registers, enter the standby mode and get ready for analogy measurements. The power on/off time related to the device is in Table 7.

Table 7. Time Required for Power On/Off

Parameter	Symbol	Condition	Min.	Typ.	Max.	Unit
POR Completion Time	PORT	Time Period After VDD and VDDIO at Operating Voltage to Ready for I ² C Command and Analogy Measurement.			350	uS
Power off Voltage	SDV	Voltage that Device Considers to be Power Down.			0.2	V
Power on Interval	PINT	Time Period Required for Voltage Lower Than SDV to Enable Next POR	100			uS

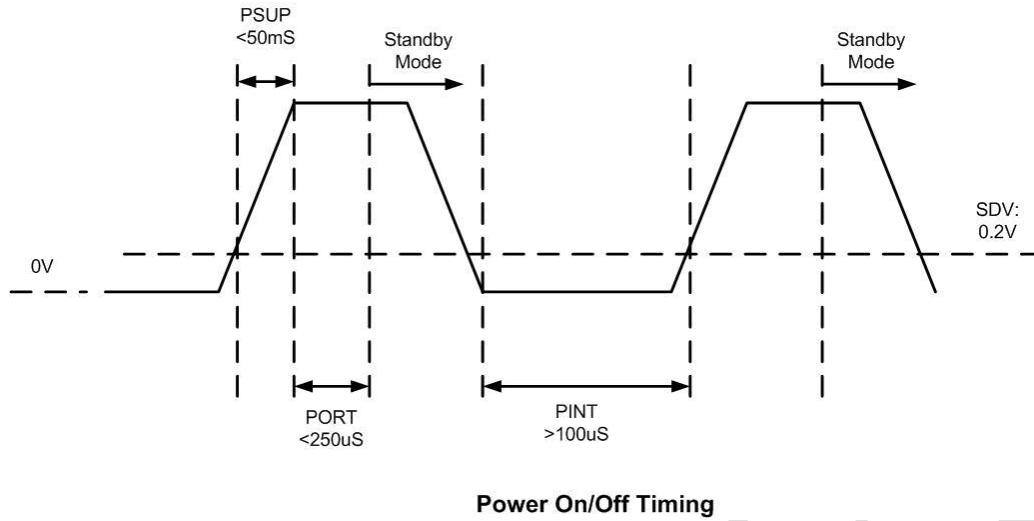

Figure 8. Power On/Off Timing

5.4 Communication Bus Interface I²C and Its Addresses

This device will be connected to a serial interface bus as a slave device under the control of a master device, such as the processor. Control of this device is carried out via I²C.

This device is compliant with I²C -Bus Specification, document number: 9398 393 40011. As an I²C compatible device, this device has a 7-bit serial address and supports I²C protocols. This device supports standard and fast speed modes, 100kHz and 400kHz, respectively. External pull-up resistors are required to support all these modes.

The default I²C address is 0D: 0001101
 If other I²C address options are required, please contact factory..

5.5 Internal Clock

The device has an internal clock for internal digital logic functions and timing management. This clock is not available to external usage.

5.6 Temperature Compensation

Temperature compensation of the measured magnetic data is enabled by default at the factory. Temperature measured by the built-in temperature sensor will be used to compensate the magnetic sensor's sensitivity changes due to temperatures. The compensated magnetic sensor data is placed in the Output Data Registers automatically.

5.7 Temperature Output

QMC5883L has a built-in temperature sensor, it can provide temperature reading for other applications. The output is placed in Temperature Output Registers (07H and 08H). The temperature is calibrated for its sensitivity.

6 MODES OF OPERATION

6.1 Modes Transition

The device has two different operational modes, controlled by register (09H), mode bits. The main purpose of these modes is for power management. The modes can be transitioned from one to the other, as shown below, through I²C commands of changing mode bits. The default mode is Standby.

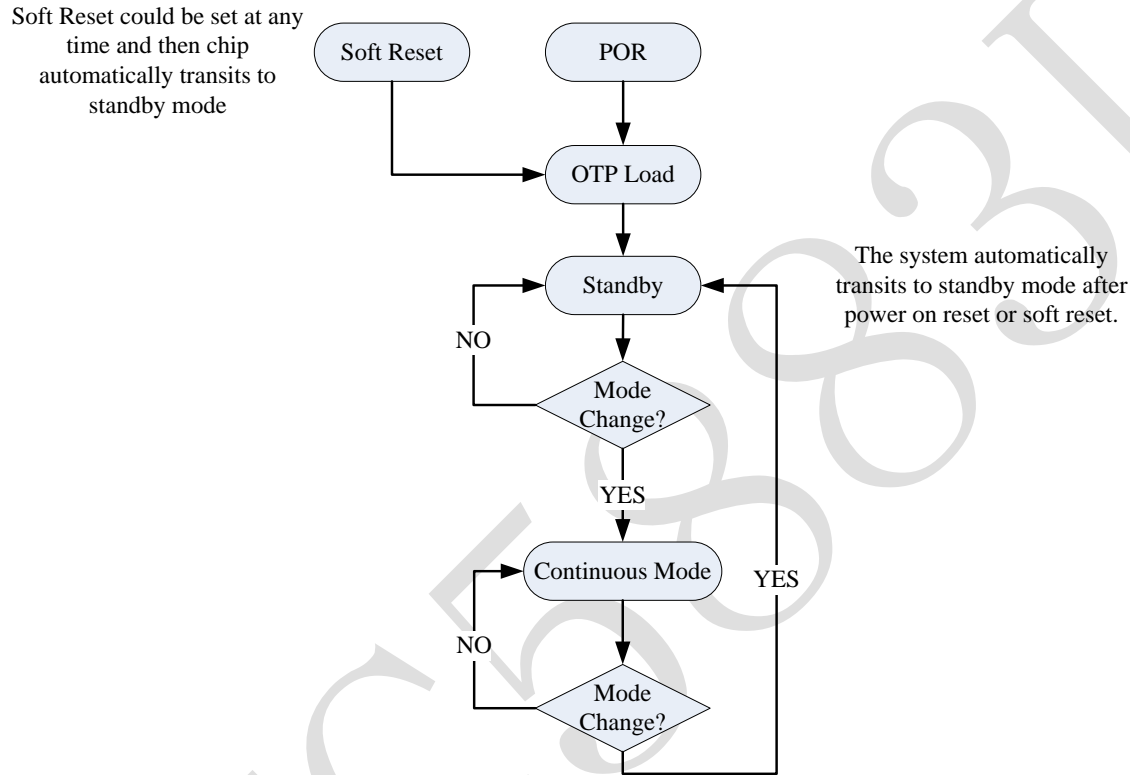

Figure 9. Modes Transition

6.2 Description of Modes

6.2.1 Continuous-Measurement Mode

During the continuous-measurement mode (mode bits= 01), the magnetic sensor continuously makes measurements and places measured data in data output registers. The field range (or sensitivity) and data output rate registers are also located in the control register (09H), they should be set up properly for your applications in the continuous-measurement mode.

For example, if the application requires output data rate 50Hz, the ODR bit in control register (09H) should be 01. If the field range is +/-8 Gauss, the RNG =01.

The over sample rate is optional for you to use. The default is OSR=00, if your application has enough resolution and need low power consumption, you may reduce OSR to a lower number, such as OSR=10 (128) or OSR =11 (64).

In the continuous-measurement mode, the magnetic sensor data are automatically compensated for offset and temperature effects. The gains are calibrated in the factory.

6.2.1.1 Normal Read Sequence

Complete magnetometer data read-out can be done as follow steps.

- ◇ Check DRDY pin or by polling DRDY bit in Register 06H
- ◇ Read DRDY bit in Register 06H (if polling, it's unnecessary)

DRDY: Data ready (“1”) or Not (“0”).
 DOR: Any data has been missed (“1”) or not (“0”)

- ✧ Read measured data, if any of the six data register is accessed, DRDY and DOR turn to “0”.
- ✧ Data protection, if any of the six data register is accessed, data protection starts. During Data protection period, data register cannot be updated until the last bits 05H (ZOUT [15:8]) have been read.

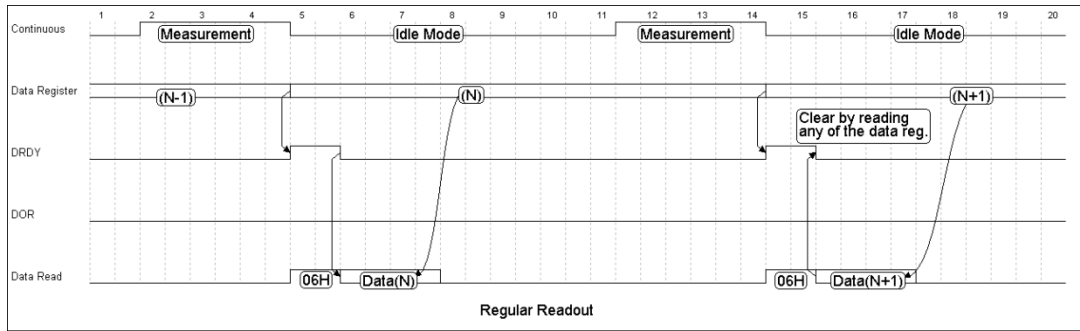

Figure 10. Normal Read Sequence

6.2.1.2 Data Read Sequence Occurs at Measurement

During measurement, it’s possible to read data register which keep the previous measured data. Therefore, no interrupt (DRDY bit) will be set if data reading occurs at the middle of measurement.

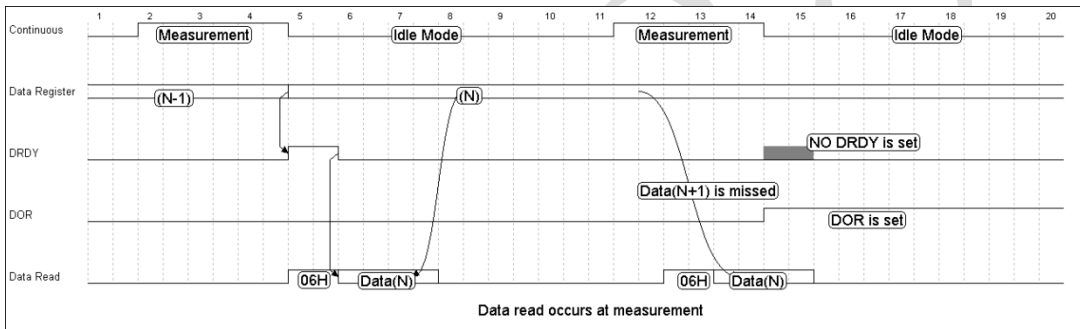

Figure 11 Data Read Sequence at Measurement

6.2.1.3 Data Not Read

If Nth data is skipped, the current data will be flushed by next coming data. In this case, interrupt (DRDY bit) keeps high until data is read. DOR bit is set to “1” which indicates a set of measurement data has been lost. DOR bit turns to “0” once 06H is accessed in next data read operation

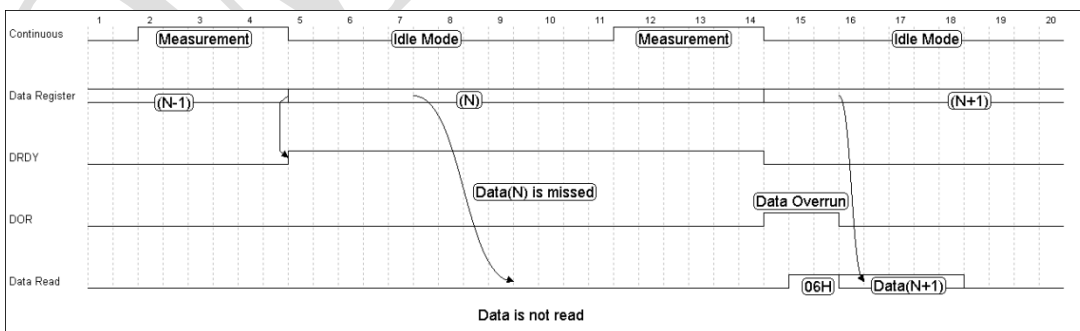

Figure 12. Sequence When Data Not Read

6.2.1.4 Data Locks Until Next Measurement Ends

Data lock is activated once any of the data register is accessed. If 05H (data unlock) is not accessed until next measurements ends, current data blocks next data to update data register. In this case, DOR bit is also set to "1" until 06H is accessed in next data read.

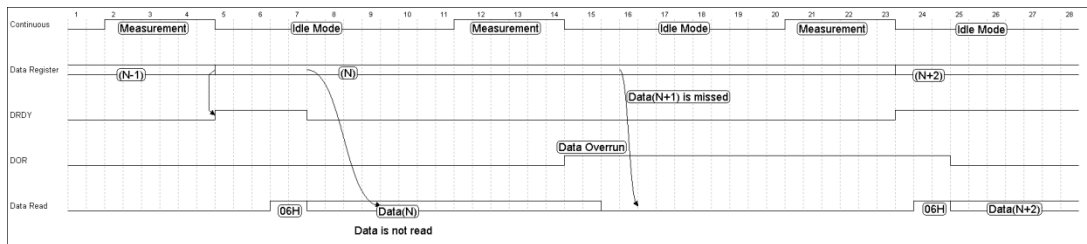

Figure 13. Sequence When Data Locks

6.2.1.5 Interrupt

An interrupt is generated on DRDY pin each time that magnetic field is measured. The interrupt can be disabled by set 0AH[0] = 1.

6.2.2 Standby Mode

Standby mode is the default state of QMC5883L upon POR and soft reset, only few function blocks are activated in this mode, which keeps power consumption as low as possible. In this state, register values are hold on by an ultra-low power LDO, I²C interface can be woken up by reading or writing any registers. There is no magnetometer measurement in the Standby mode. Internal clocking is also halted.

7 Application Examples

7.1 Continuous Mode Setup Example

- ✧ Write Register 0BH by 0x01 (Define Set/Reset period)
- ✧ Write Register 09H by 0x1D (Define OSR = 512, Full Scale Range = 8 Gauss, ODR = 200Hz, set continuous measurement mode)

7.2 Measurement Example

- ✧ Check status register 06H[0], "1" means ready.
- ✧ Read data register 00H ~ 05H.

7.3 Standby Example

- ✧ Write Register 09H by 0x00

7.4 Soft Reset Example

- ✧ Write Register 0AH by 0x80

8 I²C COMMUNICATION PROTOCOL

8.1 I²C Timings

Below table and graph describe the I²C communication protocol times

Table 9. I²C Timings

Parameter	Symbol	Condition	Min.	Typ.	Max.	Unit
SCL Clock	f_{scl}		0		400	kHz
SCL Low Period	t_{low}		1			μ S
SCL High Period	t_{high}		1			μ S
SDA Setup Time	t_{sdat}		0.1			μ S
SDA Hold Time	t_{hdat}		0		0.9	μ S
Start Hold Time	t_{hdsta}		0.6			μ S
Start Setup Time	t_{susta}		0.6			μ S
Stop Setup Time	t_{susto}		0.6			μ S
New Transmission Time	t_{buf}		1.3			μ S
Rise Time	t_r					μ S
Fall Time	t_f					μ S

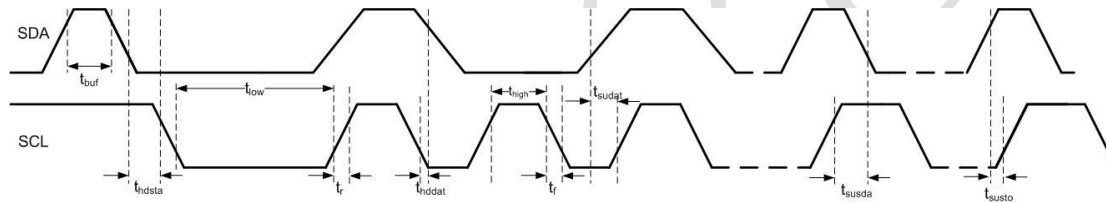

I²C Timing Diagram

Figure 14. I²C Timing Diagram

8.2 I²C R/W Operation

8.2.1 Abbreviation

Table 10. Abbreviation

SACK	Acknowledged by slave
MACK	Acknowledged by master
NACK	Not acknowledged by master
RW	Read/Write

8.2.2 Start/Stop/Ack

START: Data transmission begins with a high to transition on SDA while SCL is held high. Once I²C transmission starts, the bus is considered busy.

STOP: STOP condition is a low to high transition on SDA line while SCL is held high.

ACK: Each byte of data transferred must be acknowledged. The transmitter must release the SDA line during the acknowledge pulse while the receiver must then pull the SDA line low so that it remains stable low during the high period of the acknowledge clock cycle.

NACK: If the receiver doesn't pull down the SDA line during the high period of the acknowledge clock cycle, it's recognized as NACK by the transmitter.

8.2.3 I²C Write

I²C write sequence begins with start condition generated by master followed by 7 bits slave address and a write bit (R/W=0). The slave sends an acknowledge bit (ACK=0) and releases the bus. The master sends the one byte register address. The slave again acknowledges the transmission and waits for 8 bits data which shall be written to the specified register address. After the slave acknowledges the data byte, the master generates a stop signal and terminates the writing protocol.

Table 11. I²C Write

START	Slave Address							R W	SACK	Register Address (0x09)								SACK	Data (0x01)								SACK	STOP
	0	0	0	1	1	0	1	0		0	0	0	0	1	0	0	1		0	0	0	0	0	0	0	1		

8.2.4 I²C Read

I²C write sequence consists of a one-byte I²C write phase followed by the I²C read phase. A start condition must be generated between two phase. The I²C write phase addresses the slave and sends the register address to be read. After slave acknowledges the transmission, the master generates again a start condition and sends the slave address together with a read bit (R/W=1). Then master releases the bus and waits for the data bytes to be read out from slave. After each data byte the master has to generate an acknowledge bit (ACK = 0) to enable further data transfer. A NACK from the master stops the data being transferred from the slave. The slave releases the bus so that the master can generate a STOP condition and terminate the transmission.

The register address is automatically incremented and more than one byte can be sequentially read out. Once a new data read transmission starts, the start address will be set to the register address specified in the current I²C write command.

Table 12. I²C Read

START	Slave Address							R W	SACK	Register Address (0x00)								SACK									
	0	0	0	1	1	0	1	0		0	0	0	0	0	0	0	0										
START	Slave Address							R W	SACK	Data (0x00)								MACK	Data (0x01)								
	0	0	0	1	1	0	1	1		0	0	0	0	0	0	0	0		0	0	0	0	0	0	0	1	
MACK	Data (0x02)							MACK								MACK	Data (0x07)								MACK	STOP
	0	0	0	0	0	0	1		0		0	0	0	0	0	1	1	1		

8.2.5 I²C Pointer Roll-over

QMC5883L has an embedded I²C pointer roll-over function which can improve the data transmission efficiency. The I²C data pointer will automatically roll between 00H ~ 06H if I²C read begins at any position among 00H~06H. This function is enabled by set 0AH[6] = 01H.

9 REGISTERS

9.1 Register Map

The table below provides a list of the 8-bit registers embedded in the device and their respective function and addresses

Table 13. Register Map

Addr.	7	6	5	4	3	2	1	0	Access
00H	Data Output X LSB Register XOUT[7:0]								Read only
01H	Data Output X MSB Register XOUT[15:8]								Read only
02H	Data Output Y LSB Register YOUT[7:0]								Read only
03H	Data Output Y MSB Register YOUT[15:8]								Read only
04H	Data Output Z LSB Register ZOUT[7:0]								Read only
05H	Data Output Z MSB Register ZOUT[15:8]								Read only
06H						DOR	OVL	DRDY	Read only
07H	TOUT[7:0]								Read only
08H	TOUT[15:8]								Read only
09H	OSR[1:0]		RNG[1:0]		ODR[1:0]		MODE[1:0]		Read/Write
0AH	SOFT_ RST	ROL_P NT						INT_E NB	R/W, Read only on blanks
0BH	SET/RESET Period FBR [7:0]								Read/Write
0CH	Reserved								Read only
0DH	Reserved								Read only

9.2 Register Definition

9.2.1 Output Data Register

Registers 00H ~ 05H store the measurement data from each axis magnetic sensor in continuous-measurement. In the continuous measurement mode, the output data is refreshed periodically based on the data update rate ODR setup in control registers 1. The data stays the same, regardless of reading status through I²C, until new data replaces them. Each axis has 16 bit data width in 2's complement, i.e., MSB of 01H/03H/05H indicates the sign of each axis. The output data of each channel saturates at -32768 and 32767.

Table 14. Output Data Register

Addr.	7	6	5	4	3	2	1	0
00H	Data Output X LSB Register XOUT[7:0]							
01H	Data Output X MSB Register XOUT[15:8]							
02H	Data Output Y LSB Register YOUT[7:0]							
03H	Data Output Y MSB Register YOUT[15:8]							
04H	Data Output Z LSB Register ZOUT[7:0]							
05H	Data Output Z MSB Register ZOUT[15:8]							

9.2.2 Status Register

There are two status registers located in address 06H and 0CH.

Register 06H has three bits indicating for status flags, the rest are reserved for factory use. The status registers are read only bits.

Table 15. Status Register 1

Addr.	7	6	5	4	3	2	1	0
-------	---	---	---	---	---	---	---	---

06H						DOR	OVL	DRDY
-----	--	--	--	--	--	-----	-----	------

Data Ready Register (DRDY), it is set when all three axis data is ready, and loaded to the output data registers in the continuous measurement mode. It is reset to “0” by reading any data register (00H~05H) through I²C commands

DRDY: “0”: no new data, “1”: new data is ready

Overflow flag (OVL) is set to “1” if any data of three axis magnetic sensor channels is out of range. The output data of each axis saturates at -32768 and 32767, if any of the axis exceeds this range, OVL flag is set to “1”. This flag is reset to “0” if next measurement goes back to the range of (-32768, 32767), otherwise, it keeps as “1”.

OVL: “0”: normal, “1”: data overflow

Data Skip (DOR) bit is set to “1” if all the channels of output data registers are skipped in reading in the continuous-measurement mode. It is reset to “0” by reading any data register (00H~05H) through I²C

DOR: “0”: normal, “1”: data skipped for reading

9.2.3 Temperature Data Registers

Registers 07H-08H store temperature sensor output data. 16 bits temperature sensor output is in 2’s complement. Temperature sensor gain is factory-calibrated, but its offset has not been compensated, only relative temperature value is accurate. The temperature coefficient is about 100 LSB/°C

Table 17. Temperature Sensor Output

Addr.	7	6	5	4	3	2	1	0
07H	TOUT[7:0]							
08H	TOUT[15:8]							

9.2.4 Control Registers

Two 8-bits registers are used to control the device configurations.

Control register 1 is located in address 09H, it sets the operational modes (MODE), output data update rate (ODR), magnetic field measurement range or sensitivity of the sensors (RNG) and over sampling rate (OSR). Control register 2 is located in address 0AH. It controls Interrupt Pin enabling (INT_ENB), Point roll over function enabling (POL_PNT) and soft reset (SOFT_RST).

Two bits of MODE registers can transfer mode of operations in the device, the two modes are Standby, and Continuous measurements. The default mode after Power-on-Reset (POR) is standby. There is no any restriction in the transferring between the modes.

Output data rate is controlled by ODR registers. Four data update frequencies can be selected: 10Hz, 50Hz, 100Hz and 200Hz. For most of compassing applications, we recommend 10 Hz for low power consumption. For gaming, the high update rate such as 100Hz or 200Hz can be used.

Field ranges of the magnetic sensor can be selected through the register RNG. The full scale field range is determined by the application environments. For magnetic clear environment, low field range such as +/- 2gauss can be used. The field range goes hand in hand with the sensitivity of the magnetic sensor. The lowest field range has the highest sensitivity, therefore, higher resolution.

Over sample Rate (OSR) registers are used to control bandwidth of an internal digital filter. Larger OSR value leads to smaller filter bandwidth, less in-band noise and higher power consumption. It could be used to reach a good balance between noise and power. Four over sample ratio can be selected, 64, 128, 256 or 512.

Table 18. Control Register 1

Addr	7	6	5	4	3	2	1	0
09H	OSR[1:0]		RNG[1:0]		ODR[1:0]		MODE[1:0]	
Reg.	Definition		00	01	10	11		
Mode	Mode Control		Standby	Continuous	Reserve	Reserve		
ODR	Output Data Rate		10Hz	50Hz	100Hz	200Hz		
RNG	Full Scale		2G	8G	Reserve	Reserve		
OSR	Over	Sample	512	256	128	64		
	Ratio							

Interrupt enabling is controlled by register INT_ENB in control register 2. Once the interrupt is enabled, it will flag when new data is in Data Output Registers.

INT_ENB: “0”: enable interrupt PIN, “1”: disable interrupt PIN

Pointer roll-over function is controlled by ROL_PNT register. When the point roll-over function is enabled, the I²C data pointer automatically rolls between 00H ~ 06H, if I²C read begins at any address among 00H~06H.

ROL_PNT: “0”: Normal, “1”: Enable pointer roll-over function

Soft Reset can be done by changing the register SOFT_RST to set. Soft reset can be invoked at any time of any mode. For example, if soft reset occurs at the middle of continuous mode reading, QMC5883L immediately switches to standby mode due to mode register is reset to “00” in default.

SOFT_RST: “0”: Normal “1”: Soft reset, restore default value of all registers.

Table 19. Control Register 2

Addr.	7	6	5	4	3	2	1	0
0AH	SOFT_RST	ROL_PNT						INT_ENB

9.2.5 SET/RESET Period Register

SET/RESET Period is controlled by FBR [7:0], it is recommended that the register 0BH is written by 0x01.

Table 20. SET/RESET Period Register

Addr.	7	6	5	4	3	2	1	0
0BH	SET/RESET Period FBR [7:0]							

ORDERING INFORMATION

Ordering Number	Temperature Range	Package	Packaging
QMC5883L-TR	-40°C~85°C	LGA-16	Tape and Reel: 3k pieces/reel

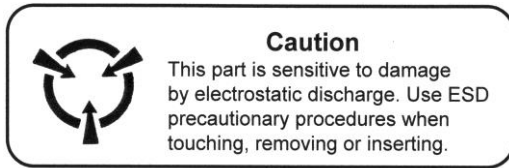

CAUTION: ESDS CAT. 1B

FIND OUT MORE

For more information on QST's Magnetic Sensors contact us at 86-21-69517300.

The application circuits herein constitute typical usage and interface of QST product. QST does not provide warranty or assume liability of customer-designed circuits derived from this description or depiction.

QST reserves the right to make changes to improve reliability, function or design. QST does not assume any liability arising out of the application or use of any product or circuit described herein; neither does it convey any license under its patent rights nor the rights of others.

U.S. Patents 4,441,072, 4,533,872, 4,569,742, 4,681,812, 4,847,584 and 6,529,114 apply to the technology described.



QST
First Floor, Building No.2,
Chengbei Road 235, Shanghai
Tel: 86-21-69517300

1.0, released Feb. 2016
QST Corporation